

EPIC-160tm

In-Dash Bass Processor/SPL Meter

Owner's Enjoyment Manual

Congratulations on your purchase of the world's finest in-dash bass restoration processor with an SPL (sound pressure level) display. Whether this is your first product from the rainforest dwellers of AudioControl or you are already a firm believer, you will definitely enjoy the EPIC-160. Remember, it comes from AudioControl, the experts at bass enhancement and building SPL displays and measurement tools.

Now before you start salivating too much just thinking about what the EPIC-160 can add to your system, take a few minutes to sit back, have a latté, decaffeinated if necessary, and read through this manual. It contains lots of useful facts and information (and besides, we spent a lot of time writing it)!!

Features Of The EPIC-160

Here are some of the cool features that are enclosed in this magical box:

- Bass restoration circuit
- SPL display up to 160 dB
- Battery Voltage indicator
- Speaker level inputs
- Para-BASS Controls
- Balanced differential inputs

AudioControl[®]

22410 70th Avenue West • Mountlake Terrace, WA 98043 USA
Phone 425-775-8461 • Fax 425-778-3166 • www.audiocontrol.com

FEATURES AND HIGHLIGHTS

Bass Restoration: The EPIC-160 contains the most popular bass maximization circuitry in the world made famous by The Epicenter. This circuit accurately recreates and injects low frequency information back into the signal path. What that means in everyday terms is that the EPIC-160 will give more bass impact to your best compact discs, MP3 tracks or even your old tapes (if you happen to have any lying around). **SPL display:** AudioControl designs and manufactures a complete line of professional real time analyzers/SPL meters and microphone calibrators that are used by professional sound contractors, studio engineers and are the standard measurement tools for sound-off organizations like IASCA and USACi. It is that background that lets us equip the EPIC-160 with a 160 dB capable microphone and SPL display.

Battery Voltage Indicator: The EPIC-160 gives you the option of measuring the SPL output of your system and it also allows monitoring of the battery voltage of your system. Wonder why your SPL is a little lower this week versus last? Many times you should check your cars electrical system to make sure it is still putting out like it used to.

Speaker Level Inputs: If you are like most people and like the look and features of your factory installed source unit but feel it's lacking power (and bass), we have good news. The EPIC-160 has a unique high impedance speaker level input that will interface with most factory installed source units (even Bose) and let you add amplifiers and speakers to your hearts content. However, unlike some of the cheesy LOC's (line output converters) available, the EPIC-160 offers a very high fidelity sound quality input.

Para-BASS™ Equalization: The EPIC-160 will increase your bass, and control it. The EPIC-160 uses our Para- BASS equalization circuit to help shape the enhanced bass to match with your speaker system.

Bulletproof Warranty: The most important feature of all. Every AudioControl product is selflessly designed and manufactured by the occupants of our rainforest factory. We take every effort to ensure that you will have many years of enjoyment out of your



EPIC-160. To ensure the performance of your new toy, we highly recommend that you allow your authorized AudioControl dealer to perform the installation. Not only do they have all the right knowledge and tools, but also in the unlikely chance the EPIC-160 should fail, we will back it with a limited five years parts and labor warranty.



Should you choose to install it yourself we will still give you one-year parts and labor warranty. To activate your warranty, you need to **FILL OUT AND SEND IN YOUR WARRANTY CARD!**

We also recommend that you save your invoice or sales slip as proof of installation and ownership. Not only is it necessary for warranty purposes, but should your EPIC-160 turn up “missing” some day while you are out watching the salmon run, you will find insurance companies are very unforgiving without proof of purchase.

We interrupt your reading of this manual to provide the impatient people with “Quick Install” information and guidelines:

The AudioControl EPIC-160 was designed to produce bass like you have never heard before. With that said it is important to take the following precautions during its use.

1. If you have an equalizer in your system, turn down any bass tone controls and initially use the EPIC-160 to pump up your bass. Otherwise, the results could be, shall we say... interesting.
2. You will want to reduce any bass tone control, loudness control, or other secondary bass controls prior to turning on the EPIC-160. Once your system is up and running, you may then opt to use them again, although we doubt it!
3. Good bass response requires an appropriate choice of speakers and amplification. Since the bass frequencies always require more power and cone area than higher frequencies...**BE PREPARED.** Small speakers (smaller than 6x9 or 8”) and lack of power will be detrimental to your system (and themselves).

*Now back to your previously interrupted Owner’s Enjoyment
Manual* —————>

Quick Install Information

The EPIC-160 needs to be installed in the signal path between a source unit and an external amplifier(s). Although it can be installed after an equalizer, it must be installed **BEFORE A CROSS-OVER**.

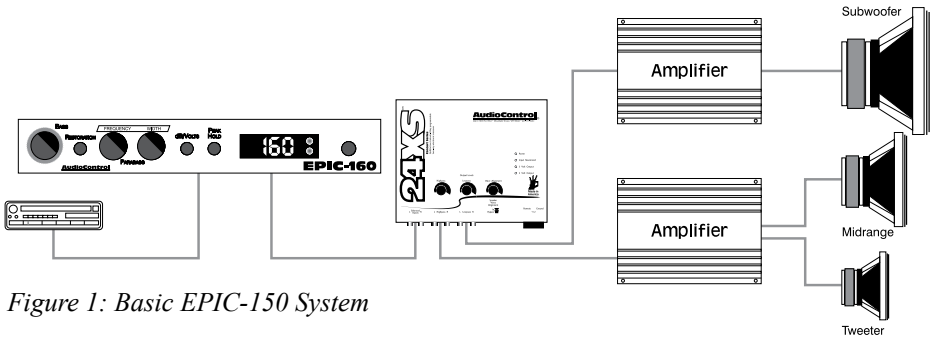

Figure 1: Basic EPIC-150 System

Once this is done, you need to hook up + 12 volt power, -12 volt ground, remote turn-on, and connect the illumination wire. If you need to know more, then read on. Heck, if you don't think you need to know more, you should still read on, because you can never know too much.

FACTORY SETTINGS

	<u>Shipped</u>	<u>Options</u>	<u>Page #</u>
Para-BASS			
Frequency Center	40Hz	27-63Hz	9
Para-BASS Bandwidth	Wide	Range from 30-250Hz	9
Input Grounding	Balanced	Unbalanced	7
Ground Isolation	Isolated	200ohm or Ground	7
Choice of beverage	Micro-brew	Latté	16

Note: Moving jumpers or adjusting the Para-BASS controls can change these configurations.

A GUIDED TOUR OF THE EPIC-160

The Front Panel

❶ **Bass Restoration Control a.k.a. “The Knob”:** This knob controls how much of the restored bass is added to your audio signal. Being that it is a knob, this means you can SLOWLY increase or decrease the amount of processed bass. (Read as: LISTEN FIRST, CRANK SECOND!)

❷ **Restoration:** By pushing in this switch you engage the bass restoration circuit.

❸ **Para-BASS Controls:** These two knobs control the Para-BASS equalization functions of the EPIC-160. The “Frequency” knob allows you to select the center frequency that you want the EPIC-160 bass maximization circuit to affect. The “Width” knob adjusts how wide of a range around the center frequency the EPIC-160 will affect.

❹ **dB/Volts:** Although this sounds like a new heavy metal group, this switch allows you to select whether the display on your EPIC-160 is showing SPL levels in dB (decibels) or electrical levels in volts. Rock on!

❺ **Peak Hold:** If you ever got high score on Space Invaders but nobody was there to watch, you know what this switch is for. When engaged, the display on your EPIC-160 will show the highest SPL or voltage reading that it measured (as long as your EPIC-160 is turned on).

❻ **SPL/Voltage Display:** This super bright display will show either the sound pressure levels or battery voltage depending on where the dB/Volts switch is set.

❼ **Bass Restoration Indicator:** If this light is flashing, your car should be bump’n!

❽ **High SPL Warning Indicator:** Since you will probably brush over our warning about SPL and potential hearing damage, this indicator light comes on at 120 dB to give you a gentle warning about how loud your system is.

❾ **160 dB Microphone:** Behind this tiny little hole is the microphone element that measures your systems SPL. Should you wish to have very low readings make sure you cover this opening.

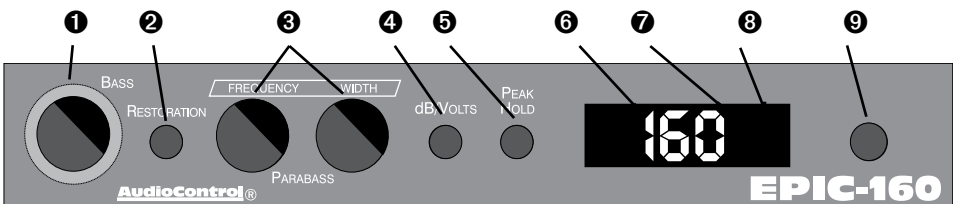

Figure 2: EPIC-160 Front Panel

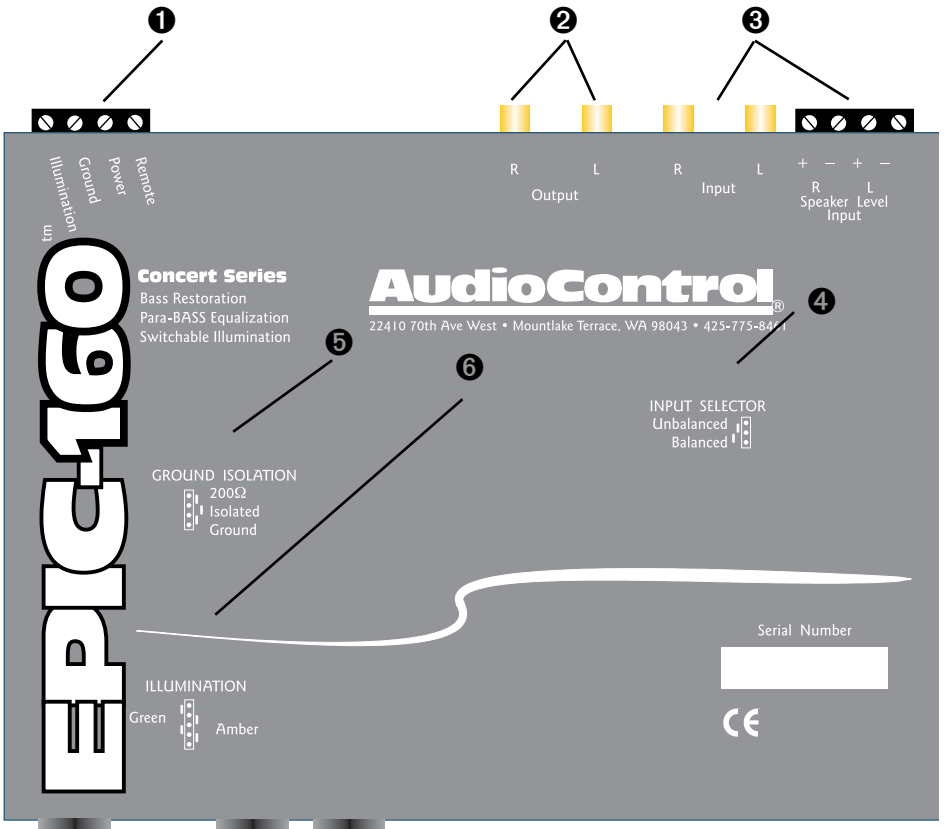

Figure 4: Top view of EPIC-160

The Top View

❶ **Power Connections:** This nifty connector is a godsend to anyone who has tried to wire up their gear with their head crammed under the dash. You can wire up the power, ground, remote turn-on, and illumination from the convenience of the driver's seat and then casually plug it in the back of your EPIC-160.

❷ **Outputs:** These RCA connectors should be connected to the next component after the EPIC-160, such as a crossover, equalizer, or amplifier. Just remember, for maximum performance the EPIC-160 *must* go before any crossovers!

❸ **Inputs:** The EPIC-160 has two sets of quick inputs, MAIN and SPEAKER LEVEL. These inputs should get their signals from the main source unit/head unit and should attach to *either* RCA jacks *or* speaker leads that are coming out of your source unit.

Selector

❹ **Input Grounding:** For most systems you can leave this jumper set in the BALANCED position. In some systems, the source unit may look for a ground through the RCA connection to the amplifier and create a ground loop, which in turn can cause a whine in your system (we are not talking about Pinot Noir). In that event, you should go ahead and change the jumpers to the UN-BALANCED position.

❺ **Illumination Selection:** These jumpers let you switch the backlight illumination from green to amber. Given our devotion to protect the Rainforest, the EPIC-160 is shipped in the green mode.

❻ **Ground Isolation Selector:** Occasionally alternator whine may appear in a system because the source unit and amplifier are using different grounding schemes. To help in this situation, we have provided alternative grounding connections. *Make sure your*

The Story Behind The Epicenter Bass Restoration Technology

Now that you have purchased the EPIC-160 you may ask yourself, “Why would I need to restore bass?” The truth is that during the recording process, low frequency information can be “mixed” down or filtered out during the recording process. It’s not that recording engineers are out to get you; in fact they are looking out for your best interest and are concerned that many speakers systems can not handle “truly” low bass information.

The circuit inside the EPIC-160 is designed to reproduce the low frequency information by looking at the upper frequency ranges and detecting musical harmonics. These harmonics then allow The Epicenter circuitry to drop a few octaves and reproduce the “missing” bass notes.

The bottom line is that The Epicenter technology gives you deep, body shuddering, heart stopping bass. Can you handle it?

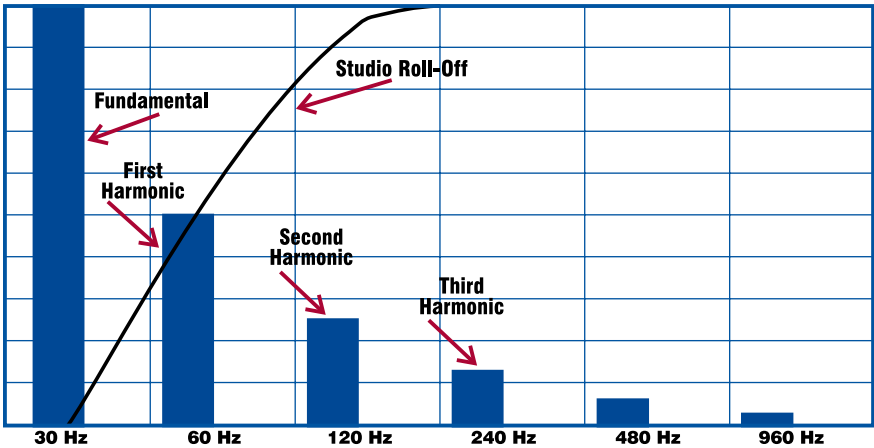

Figure 5: How The Epicenter Circuitry Works

HOW MUCH DO YOU REALLY KNOW ABOUT SPL LEVELS?

Before you go out and design yourself a 140 dB plus SPL monster, you might want to consider the following:



Nuclear Explosion	200 dB +
Airplane Engine take off at 100 feet	140 dB
Jack Hammer	130 dB
Normal conversation speech	60 dB

If you have dreams of rocking around your neighborhood, blowing away Mr. Rogers and all your friends with decibel levels of 160 or higher, you might think twice. In fact, in many areas if your place of employment is louder than 85 dB, your boss is obligated to provide you with ear protection. Therefore, should you choose to expose yourself to SPL greater than 100 dB by cranking up your system, you should utilize some sort of ear protection.

Now we don't want to rain on your parade or discourage you from "letting it loose", but do be careful with your ears because like your brain cells, once your hearing is gone, it don't come back. Of course always avoid inhaling, especially through your ears. Since many of you get caught listening to your music, we have equipped your EPIC-160 with a warning LED that comes on when it measures sound pressure levels greater than 120 dB. Above 120 dB you must use hearing protection to avoid damage!

INSTALLING THE EPIC-160

Up to this point everything you have read has served to educate you on the operations of the EPIC-160. We are sure that you are chomping at the bit to install the EPIC-160 so we recommend you read the following sections very carefully.

A. Placement & Mounting Of The EPIC-160

Placement: By definition, the EPIC-160 in-dash processor was designed to be installed on or near the dashboard of most cars. Regardless of where you "physically" install the EPIC-160, it needs to be placed in the signal path as close to your source unit as possible; definitely BEFORE any crossover circuit.

Mounting: The EPIC-160 is flexible enough to mount almost anywhere, although somewhere on the dash or in a center console is the most logical. You will want to be able to access it while you are sitting in the driver's seat of your vehicle. The EPIC-160 is designed to be mounted almost anywhere in a vehicle, although it is recommended to avoid hot spots like the firewall, engine compartment, or tail pipe. The mounting location must also be safe from water seepage or areas with bad seals (rubber gaskets, not sleek furry mammals who eat salmon). If there are old (or new) water stains, stay away. We have provided brackets to assist you in mounting the EPIC-160 chassis under your dashboard or wherever you may choose. The screw holes on the EPIC-160 chassis also allow for easy installation underneath a radio or with a dash kit. It is of utmost importance to mount the EPIC-160 securely to avoid any undue stress or breakage from over acceleration or braking.

B. EPIC-160 Power Wiring

• **ENLIGHTENING INFO** • Disconnect the negative terminal of your car's battery before working on any electrical connections. Failure to do so could lead to a dramatic spark in your life.

Remote Turn-On: Connect a 22 to 18 gauge wire from the head-unit's remote turn-on to the "Remote" connector on the EPIC-160.

Positive (+12V) Connection: Insert an 18 gauge or larger wire into the connector labeled "Power" on the nifty connector of your EPIC-160. Connect it to a good, fused (1 amp), constant source of 12 volts (we suggest the battery.)

Ground Connection: Use the same gauge wire as you did for the positive connector and run it from the "Ground" connector on the EPIC-160 to the negative terminal of the battery, a ground buss, or a verified ground location. The factory head unit ground is **NOT** recommended.

Illumination: The connector labeled "Illumination" on your EPIC-160 controls the backlighting of your unit. If you run a wire from this connector to a switched 12-volt source, such as the "Remote" turn on wire on your source unit, you light up the backlighting on the EPIC-160. A better idea is to connect the illumination wire to a factory dash light dimmer and you now have the ability to dim the backlighting of the EPIC-160 with your dash lights.

C. EPIC-160 Audio Wiring

Planning: As you may already have guessed, there are numerous ways to configure the EPIC-160 in your audio system. Spend a little quality time planning out your system and even sketching it out on paper if you can. The following diagrams are just a few of the system options:

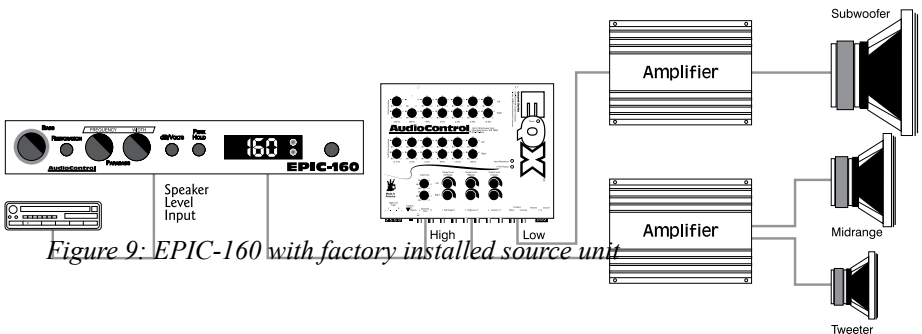
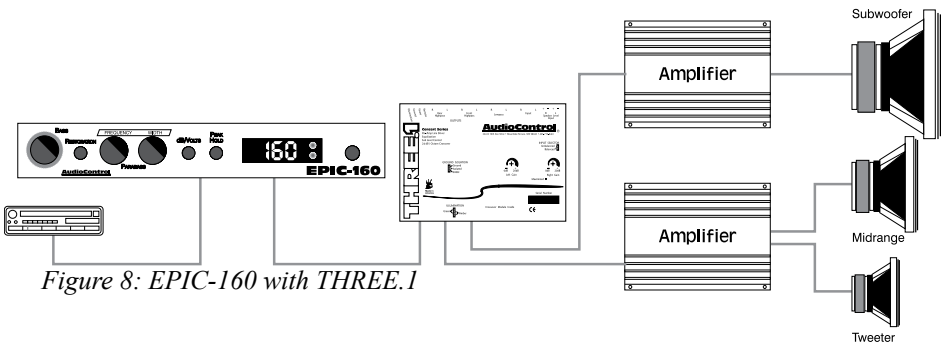
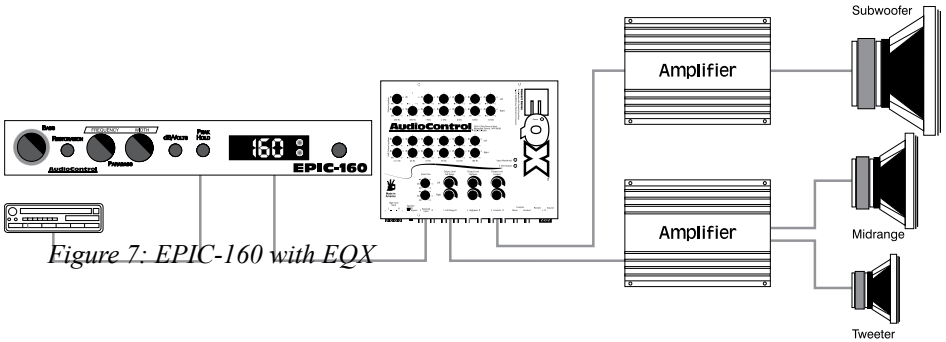

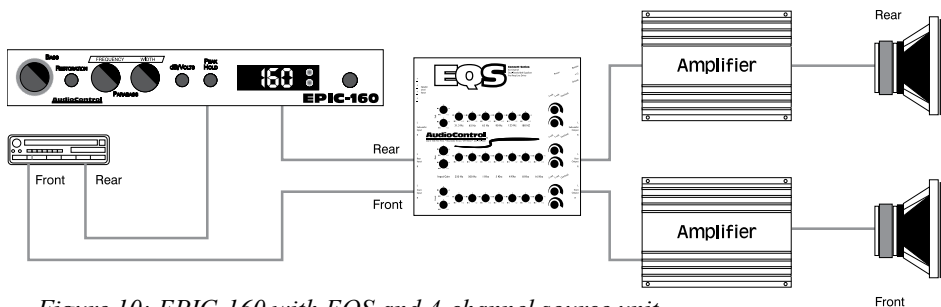

Figure 10: EPIC-160 with EQS and 4-channel source unit

Adjusting the Para-BASS Controls

The bass response in a system is affected by four factors (1) the acoustics of the vehicle, (2) the location of the speakers, and (3) the music on the tape, CD, or source unit, and (4) amplifiers, speakers and speaker enclosures. Because of the variations in the recording process, we developed the EPIC-160 to help restore any low frequencies lost during the recording process. However, the acoustics of various environments are different. With this in mind our coffee-laden engineers developed the unique Para-BASS™ system.

The “Frequency” control allows you to select a center frequency (the frequency most affected) between 27 and 63 Hz. The “Width” control then allows you to control the shape of the filter centered on the “Frequency”. You will want to use a real time analyzer or a good set of ears to set this control.

TROUBLESHOOTING

No Power: If the Power LED on your EPIC-160 will not turn on, check to make sure that the power wire and remote turn on wires are connected or a fuse has not blown.

No Bass Restoration: When your system is playing and yet you don’t hear any difference in the sound, trying turn the knob clockwise. If you still don’t hear any affect, then check to make sure that you have the EPIC-160 in the right part of the signal chain. It *must* be installed **BEFORE** any crossovers in the system.

Note: If you are using a source unit with a built in crossover or processor, you must run a full range output to the EPIC-160’s inputs.

Sounds Distorted: Should your system sound distorted or your speakers are moving *way too* much, you should decrease the amount of bass restoration by turning the dash control knob counter clockwise.

No Display: The display on your EPIC-160 should always be showing either the systems SPL or the battery voltage. If the display is showing nothing, see the above section on “No Power”.

IF YOU LIKE THE EPIC-160, YOU’LL LOVE...

The **EQL Concert Series** is our award winning dual bandwidth, trunk mount equalizer. Thirteen full octave and 1/2-octave spaced bands help tame even the most wicked acoustical environment, your car. Need a crossover and an equalizer. The **EQX Concert Series** is just the ticket.



The **3XS™** is a 4 channel, 2-way crossover with breathtakingly steep 24dB per octave slopes. If performance is important to you, then you will appreciate the 3XS.

If more signal voltage is necessary in your system, don't feel alone. Many customers have

added **Overdrive or Matrix** line drivers and felt like they had new amplifiers in their systems.

Do you want to make your home audio system sound just as good as your car audio system? Good news! AudioControl makes a complete line of products signal processors that do the same amazing things for your home audio or theater system.



And now a word from the legal department...

THE WARRANTY

People are scared of warranties. Lots of fine print. Months of waiting around. Well, fear no more, this warranty is designed to make you rave about us to your friends. It's a warranty that looks out for you and helps you resist the temptation to have your friend, "...who's good with electronics", try to repair your AudioControl product. So go ahead, read this warranty, and then take a few days to enjoy the EPIC-160 before sending in the warranty card and comments.

"Conditional" doesn't mean anything ominous. The Federal Trade Commission tells all manufacturers to use the term to indicate that certain conditions have to be met before they'll honor the warranty. If you meet all of these conditions, we will warrant all materials and workmanship on the EPIC-160 for one year from the date you bought it (five years if it is installed by an authorized United States AudioControl dealer). We will fix or replace it, at our option, during that time.

Here are the conditional conditions:

1. You have to fill out the warranty card and send it to us within 15 days after purchasing the EPIC-160.
2. You must keep your sales receipt for proof of purchase showing when and from whom the unit was bought. We're not the only ones who require this, so it's a good habit to get into with any major purchase.
3. Your EPIC-160 must have originally been purchased from an authorized AudioControl dealer. You do not have to be the original owner, but you do need a copy of the original sales slip.
4. You cannot let anybody who isn't: (A) the AudioControl factory; (B) somebody authorized in writing by AudioControl to service your EPIC-160. If anyone other than (A) or (B) messes with your EPIC-160, that voids your warranty.

5. The warranty is also void if the serial number is **altered or removed**, or if the EPIC-160 has been used improperly. Now that sounds like a big loophole, but here is all we mean by it. Unwarranted abuse is: (A) physical damage (don't use the EPIC-160 for a jack stand); (B) improper connections (120 volts into the power jack can fry the poor thing); (C) sadistic things. This is the best mobile product we know how to build, but if you mount it to the front bumper of your car, something will go wrong.
6. If an authorized United States AudioControl dealer installs the EPIC-160, the warranty is five years.

Assuming you conform to 1 through 6, and it really isn't all that hard to do, we get the option of fixing your old unit or replacing it with a new one.

LEGALESE SECTION

This is the only warranty given by AudioControl. This warranty gives you specific legal rights that vary from state to state. Promises of how well the EPIC-160 will perform are not implied by this warranty. Other than what we have covered in this warranty, we have no obligation, express or implied. Also, we will not be obligated for direct or indirect consequential damage to your system caused by hooking up the EPIC-160.

Failure to send in a properly completed warranty card negates any service claims.

THE EPIC-160 SPECIFICATIONS

All specifications are measured at 14.4 VDC (standard automotive voltage). As technology advances, AudioControl reserves the right to continuously change our specifications, like our weather, although we *are* working on it.

Maximum input level.....	15 Vrms
Maximum output level.....	13.5 Vpeak
Frequency response.....	10Hz-100kHz; +/-1dB
Total harmonic distortion.....	0.003%
Signal to Noise ratio.....	- 130dB
Balanced input noise rejection.....	60dB
Microphone acoustical level.....	70 dB to 160 dB
High SPL Warning.....	120 dB
Input Impedance.....	10 Kohms
Output Impedance.....	160 Ohms
Power supply.....	High headroom PWM
Power draw.....	300mA
Recommended fuse rating.....	1 Amp
Size.....	6.75" W x 5" D x 1" H
Weight.....	2 lbs

AudioControl

making good stereo sound better[®]

22410 70th Avenue West

Mountlake Terrace, WA 98043

Phone 425-775-8461 • Fax 425-778-3166

www.audiocontrol.com

© 2003, AudioControl, a division of Electronic Engineering and Manufacturing, Inc.

All rights reserved

AudioControl, Making Good Stereo Sound Better, Performance Match, The Epicenter, EQL, EQX, and EPIC-160 are all trademarks of Electronic Engineering and Manufacturing, Inc.

This literature was conceived, designed, and written on a bleak, windy, and dreary rain-drenched day at our home in the Pacific Northwest Rainforest. The wheat beer was cold and so was the weather.