

Installation Examples and Hookup Diagrams

The Simple, but Killer, Competition Two-way system

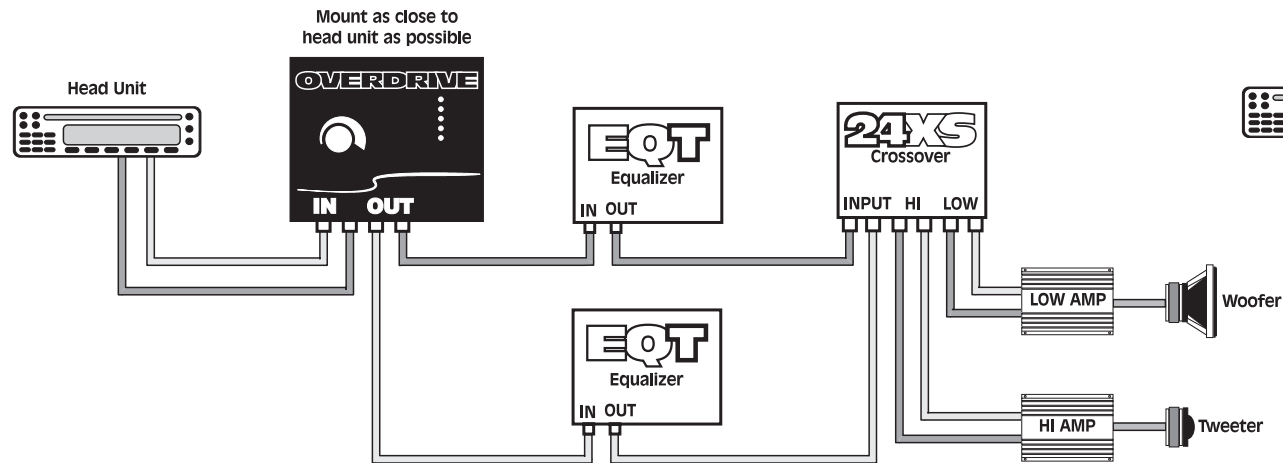

Competition Two-way System

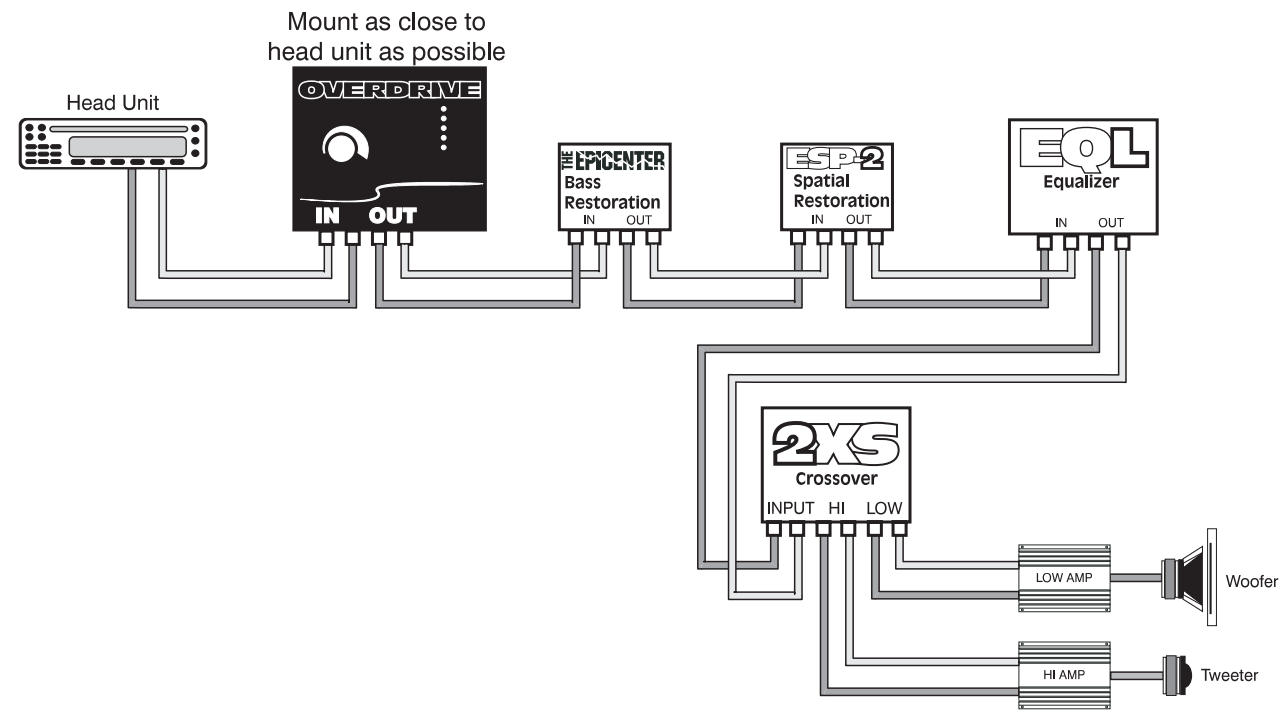

Four Channel System with Two Overdrives

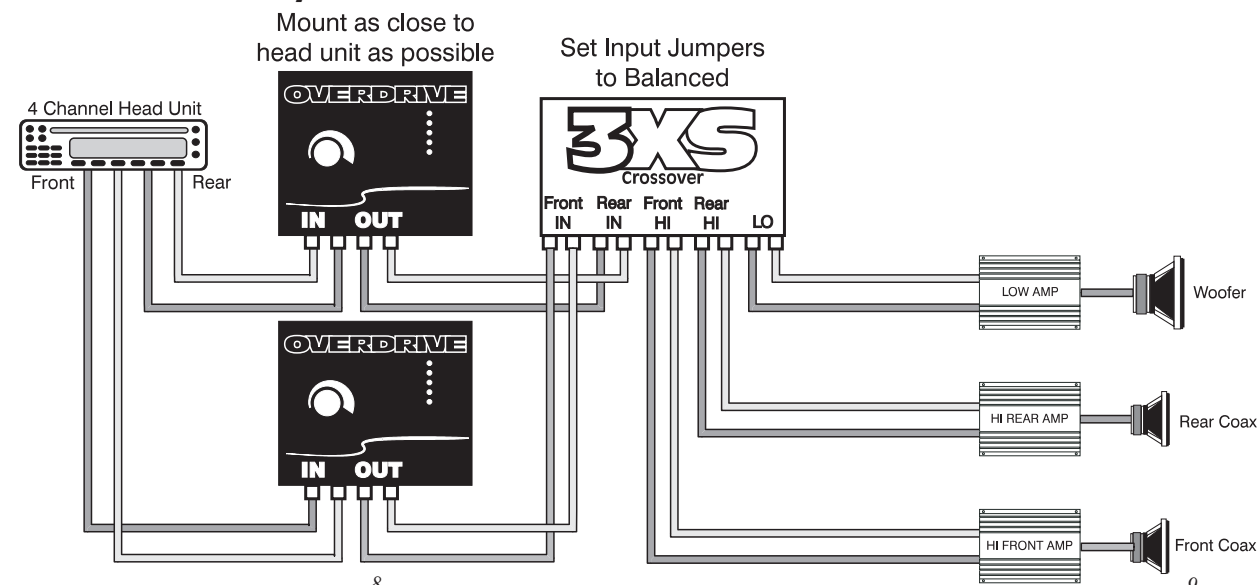

Two-way System with Passive Crossover

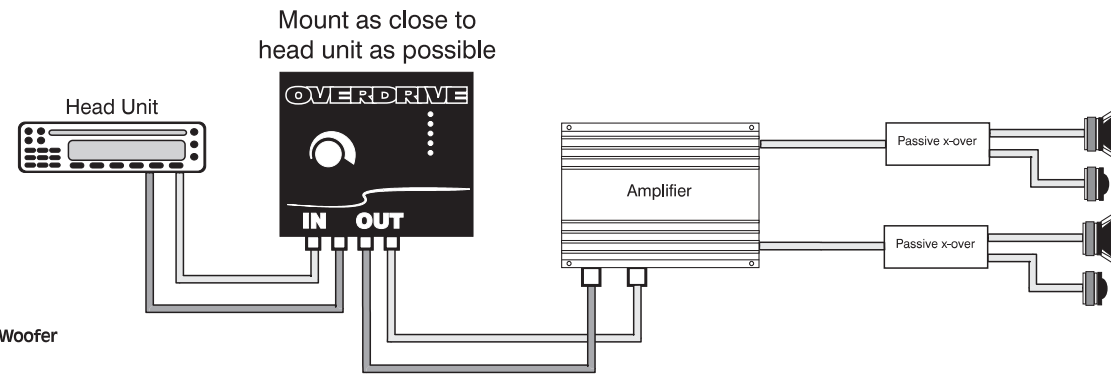

Installation Precautions/Hints

Do not mount the OVERDRIVE Line Driver where it will be exposed to outside elements or extreme temperatures. Avoid areas of severe vibration or shock. The front bumper is off limits.

- Mount the OVERDRIVE as close to the head unit as possible. Absolutely mount it at the front of the vehicle.
- Use high quality, 100% shielded audio cables.
- Plan on a single-point (star ground) scheme so all components, including the head unit, connect to a common ground point. Use no less than 14 gauge wire for the power and ground connections.
- Make certain that there are no fuel lines, brake lines, electrical wires or anything else that you don't want to run a drill bit through. That includes things on the back side of that floor panel you're about to punch a hole in.
- Make certain the OVERDRIVE is firmly mounted with screws so it won't come flying off the next time you blast over a speed bump.
- Adjust the Overdrive for the maximum that the next component in the chain can handle. Make certain that whatever component you put after the OVERDRIVE can withstand the output voltage you dial up. The inputs to many crossovers and amplifiers will clip around 2 volts. All AudioControl products can handle inputs from 5 to 9 volt RMS.
- Turn down your amp gains to their minimum setting. Then you can run a higher signal (better signal to noise) into the amplifiers. Don't worry, your amps will still go to full output (unless they actually MUTE when at minimum). For more information on this, ask us for Tech Note 1006.

Blatant Plug

The OVERDRIVE Line Driver is part of the AudioControl Performance Match Series of products. The Performance Match products will extract killer performance from your car stereo system.

There are real world barriers to good autosound such as the fact that doors and trunks rarely make good speaker boxes. AudioControl Performance Match products like the Concert Series 2XS™ and 3XS™ crossovers; the Concert Series EQL™, EQX™, and EQT™ equalizers; and The Concert Series Epicenter bass maximizer will help you overcome those barriers. AudioControl components make it easy to adjust or “voice” components to the specific acoustics and hostile elements of your stereo system whether it's a sleek Honda or stylish ThunderBird. The result is, as one warranty card stated, “A dream come true.”

And now a word from the legal department...

The WARRANTY

People are scared of warranties. Lots of fine print, lots of noncooperation, months of waiting around. Well, don't be scared of this warranty. It's designed to make you rave about us to your friends. It's a warranty that looks out for you and helps you resist the temptation to have your friend “who's good with electronics” try to repair your AudioControl OVERDRIVE. So go ahead and read this warranty, then enjoy your new component for a few days before sending in the warranty card and comments.

“Conditional” doesn't mean anything ominous. The Federal Trade Commission tells all manufacturers to use the term to indicate that certain conditions have to be met before they'll honor the warranty. If you honor these conditions, we will warrant all materials and workmanship on your OVERDRIVE for five years from the date you bought it, if installed by an authorized AudioControl dealer, and will fix or replace it, at our option, during that time.

Here are the conditions that make this warranty conditional:

1. You have to fill out the warranty card and send it to us within 15 days after you purchase your OVERDRIVE.
2. You must keep your sales slip or receipt so you have proof when and from whom you bought your OVERDRIVE. We're not the only company to require this, so it's a good habit to be in with any stereo purchase.
3. Your OVERDRIVE has to have been originally purchased from an authorized AudioControl dealer. You do not have to be the original owner to take advantage of the warranty, but the date of purchase is still important, so be sure to get a copy of the sales slip from the original owner.
4. You cannot let anybody who isn't: (a) the AudioControl Factory; (b) an authorized service center; or (c) someone authorized in writing by AudioControl service your OVERDRIVE. If anyone other than (a), (b) or (c) messes with your OVERDRIVE, that voids the warranty.
5. The warranty is also void if the serial number has been altered or removed, or if the AudioControl OVERDRIVE is used improperly. Now, that sounds like a big loophole, but here is all we mean by it.

Unwarranted abuse is: (a) physical damage (our mobile products are not meant to be used as jack stands for your car); (b) improper connection (we have done the best we can to protect the inputs, however, 120 volts into the jacks can fry the innards of the poor beast); (c) sadistic things.

This is the best mobile product we know how to manufacture, but if you use it for the front bumper of your Baja bug and get it full of water and dirt, things will go wrong.

Assuming you conform to numbers 1 through 5, and it isn't all that hard to do, we get the option of deciding whether to fix your old unit or replace it with a new one.

Legalese Section

This is the only warranty given by AudioControl. This warranty gives you specific legal rights which vary from state to state.

Promises of how well your OVERDRIVE will work are not implied by this warranty. Other than what we've covered in this warranty, we have no obligation, express or implied. Also, we will not be obligated for direct or indirect consequential damage to your system caused by hooking up the AudioControl OVERDRIVE.

Failure to send in a properly-completed warranty card negates any service claims.

